

IMPULSE® G+ Mini Drive Operational Manual

OVERVIEW

The following procedure is a supplement to other documentation available for the IMPULSE® G+ Mini drive. This will guide the user in proper installation and setup of the system.

⚠ DANGER! DANGEROUS VOLTAGES ARE PRESENT WHEN DRIVE IS ON. Improper wiring can cause bodily harm and damage to the equipment. Before applying power to the IMPULSE® G+ Mini, ensure that all protective covers are fastened and all wiring connections are secure. After power has been turned OFF, wait at least 5 minutes until the charge indicator extinguishes completely before touching any wiring, circuit boards, or components.

When installing the system, be sure to follow good wiring practices and follow all applicable electrical codes. Ensure that the mounting of all components are secure and the environment, such as excessive moisture, poor ventilation, etc., will not cause system degradation.

Read this document, provided with the IMPULSE® G+ Mini, thoroughly before attempting installation. Refer to the technical manual, as needed, available at:
<http://www.magnetekmh.com/Material%20Handling/Product%20Manuals>

Step 1

Connect Motor and Line Power

Figure 1 shows the electrical connections for the input power and motor terminals on the IMPULSE® G+ Mini drive. Make the appropriate connections, with power turned off. Follow good wiring practices and follow all applicable electrical codes. Ensure the equipment is properly grounded, as shown.

⚠ WARNING: DO NOT CONNECT ANY OF THE FOLLOWING TERMINALS TO EARTH GROUND.

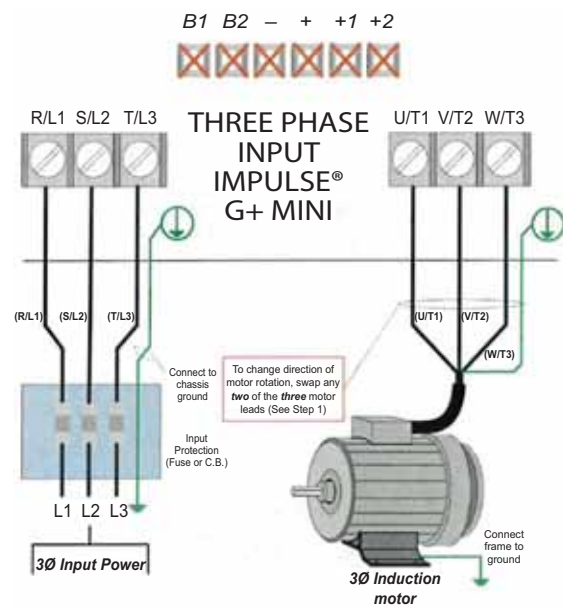
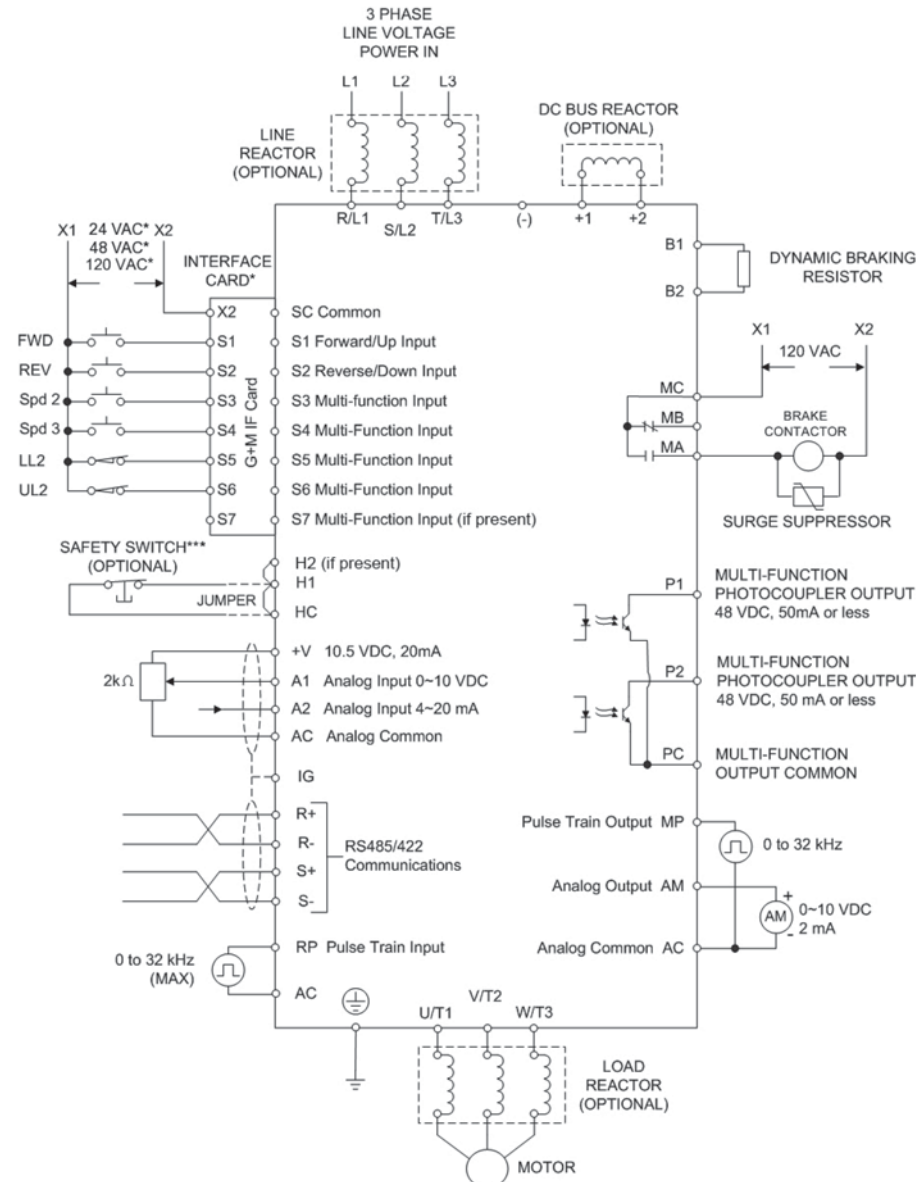

Figure 1: Input Power and Output Motor Connections

Step 2

Typical Connection Diagram

This step shows a typical wiring diagram and connection points for the IMPULSE® G+ Mini. Wiring connections should only be made by trained and authorized personnel when power to the drive is turned off.



* 24VDC interface is standard. 120VAC, 42-48VAC, and 24VAC is optional.
** Optional P3S2-OUT2 card provides two 240 VAC, 1.5 Amp solid-state relay outputs (panel-mounted).
*** In accordance with UL508C, EN954-1 Safety Category 3, and EN61508, SIL2.

Figure 2: Typical Connection Diagram

Step 3

Changing Parameters and Monitoring the IMPULSE® G+ Mini

This step shows how to access and modify an IMPULSE® G+ Mini parameter as well as how to monitor IMPULSE® G+ Mini signals such as output frequency and motor current.

Make sure all protective covers have been re-attached and power is turned on. DO NOT RUN THE MOTOR.

Accessing Parameter Menu & Changing Parameters



Figure 3: IMPULSE® G+ Mini Digital Operator Power-up State

Press **↓** four times until the digital operator shows the parameter menu (PAR) then press **ENTER**.



Figure 4: Select Parameter Value

Press **→** to select the digit you would like to change. Next use **↑** and **↓** to select the parameter group, sub-group, or number.



Figure 5: Select Parameter

Modify the parameter value using **↑** and **↓**. Press **ENTER** to save the new value.



Figure 6: Change Parameter Value

Press ESC several times to return to the main display.

Monitor Motor Frequency and Motor Current



Figure 7: IMPULSE® G+ Mini Digital Operator Main Display

Press **▲** until the FOUT LED turns on. The display now shows the actual drive output frequency in Hz.



Figure 8: Output Frequency

Pressing **▲** again will show the motor output current in Amps.

NOTE: Refer to the technical manual on how to access other drive monitors.



Figure 9: Motor Current

Step 4

Selecting a Control Method and Motion

This step will explain how to configure the drive for a Hoist or Traverse application. For hoisting applications, the IMPULSE® G+ Mini should only be used to control a hoist with a mechanical load brake.

Traverse:

Set parameter A01.03 = 0 (Traverse).
It is recommended that the Control Method is set to V/f (A01.02 = 0).
If Open Loop Vector is desired, set A01.02 = 2.

Hoist (with Mechanical Load Brake):

Set parameter A01.03 = 1 (Hoist).
It is recommended that the Control Method is set to V/f (A01.02 = 0).
If Open Loop Vector is desired, set A01.02 = 2.

NOTE: An Auto-tune is recommended when using the Open Loop Vector Control method or Hoist motion.

Step 5

Selecting a Speed Reference

This step will list the speed reference settings that are selected with parameter A01.04.

NOTE: Default speed settings will be automatically applied via X-Press Programming. Reference the technical manual for more details and wiring instructions.

2-Speed Multi-Step: A01.04 = 0

3-Speed Multi-Step: A01.04 = 1

5-Speed Multi-Step: A01.04 = 2

2-Step Infinitely Variable: A01.04 = 3

3-Step Infinitely Variable: A01.04 = 4

Uni-Polar Analog: A01.04 = 5

Step 6

Auto-Tuning

In this step the IMPULSE® G+ Mini is set up for use with the motor. Make sure all protective covers have been re-attached and then apply power to the IMPULSE® G+ Mini. DO NOT RUN THE MOTOR.

NOTE: Auto-Tuning will not function properly when a brake is engaged. Ensure the motor shaft can freely rotate. Never perform an Auto-Tune with motor connected to a load.

Press **▲** three times until the Digital Operator shows the Auto-Tuning menu (A. Tun) then press **ENTER**.

Press **▲** once until the Digital Operator shows parameter T01.02 then press **ENTER**.

For Europe: Enter Motor Power in kW
For USA: Enter Motor Power in HP

Press **RESET** to select the digit you would like to change and use the **▲** and **▼** to adjust the value, then press the **ENTER** to save the value.

Press **▲** to go to select the next parameter and follow the same procedure described above to adjust its value.

- T01.02** Motor Rated Voltage (e.g. 230 V, 460 V)
- T01.03** Motor Rated Current (e.g. 11.0 A, 22.0 A)
- T01.04** Motor Base Frequency (e.g. 60.0 Hz)
- T01.05** Motor Poles (e.g. 4 Poles)
- T01.06** Motor Rated Speed (e.g. 1750 rpm)

After setting parameter T01.07 press **▲** to select the Auto-Tuning command.

WARNING! SUDDEN MOVEMENT HAZARD. The IMPULSE® G+ Mini and motor may start unexpectedly during Auto-Tuning.

WARNING! ELECTRIC SHOCK HAZARD. High voltage will be supplied to the motor when Auto-Tuning is performed. Do not touch the motor.

Next, press **ENTER** on the Digital Operator. The IMPULSE® G+ Mini will now start the Auto-Tuning procedure.

The display will show **End** when the Auto-Tuning procedure has been successfully completed. Please reference the IMPULSE® G+ Mini technical manual or repeat Auto-Tuning procedure again if the display shows an error message.

Step 7

Quick Start Parameters

The following table lists the general purpose application parameters as well as frequently asked questions.

This section may require you to change one or more IMPULSE® G+ Mini parameters. Please refer to Step 3 for a detailed explanation on how to change parameters.

Parameter	Description	Settings	Comments
A01.01	Access Level	0 = User 1 = Basic 2 = Advanced	
A01.02	Control Method	0 = V/f 2 = Open Loop Vector*	* Auto-Tune recommended
A01.03	Motion	0 = Traverse 1 = Hoist 4 = Braketric	
A01.04	Speed Reference	0 = Two-Speed Multi-Step 1 = Three-Speed Multi-Step 2 = Five-Speed Multi-Step 3 = Two-Step Infinitely Variable 4 = Three-Step Infinitely Variable 5 = Uni-Polar Analog (0-10VDC, 4-20mA)	
B01.01 - 16	Speed References	0.00 - 150.00 Hz	Limited by E01.04
B05.01	Acceleration Time	0.0 - 25.5 Seconds	
B05.02	Deceleration Time	0.0 - 25.5 Seconds	
E01.01	Input Voltage	155 - 255 VAC (200 VAC Models) 310 - 510 VAC (400 VAC Models)	Line Voltage
E02.01	Motor Rated FLA	0.01 - 70.0 Amps	See Motor Nameplate
H01.xx	Digital Inputs		Terminals S1 - S7
H02.xx	Digital Outputs	See Instruction Manual for Options	Terminals MA/MB, P1, P2
H03.xx	Analog Inputs		Terminals A1, A2
H04.xx	Analog Output		Terminal AM

Frequently Asked Questions

Question: How do I reset the drive back to factory default settings?
Answer: Go to parameter A01.05 and enter 1110.

Question: How do I adjust the time it takes the motion to speed up or slow down?
Answer: Adjust the acceleration time parameter B05.01 and deceleration time B05.02.

Question: How do I prevent my drive from tripping on an OV fault (overvoltage) while my motor is ramping down?
Answer: Increase deceleration time parameter B05.02 and check braking resistor.

Question: How do I prevent my drive from tripping on an OL1 fault (overload) while my motor is ramping down?
Answer: Verify motor rated current parameter E02.01 and motor overload parameter settings L01.01 Motor overload selection, L01.02 Motor overload protection time.

Question: How can I run my motor above the nominal motor speed?
Answer: Increase the value of parameter E01.04 Maximum Frequency. Verify that the motor and system allow for this.

Question: How can I change motor direction without changing the motor leads?
Answer: Set parameter B03.04 to 1 (exchange phases).